

FLAT

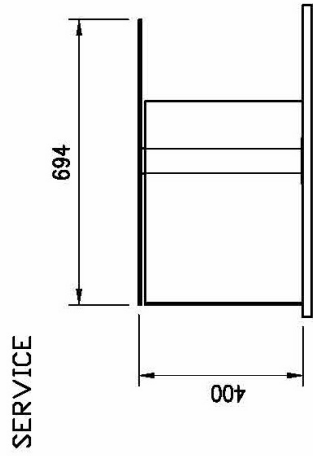

SERVICE

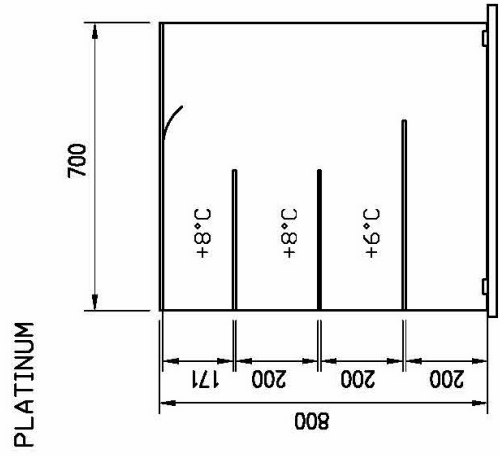

PLATINUM

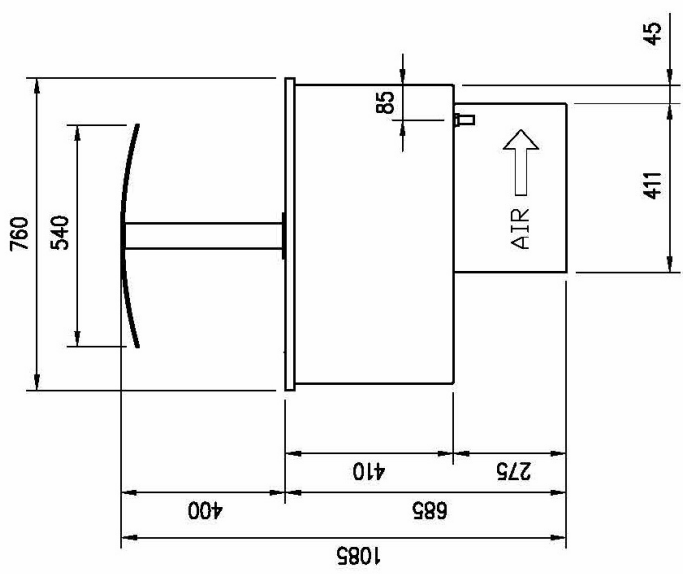

GN	L1	L2	HOLE
4/1	1494	744	1460x726
5/1	1819	744	1785x726
6/1	2144	1069	2110x726

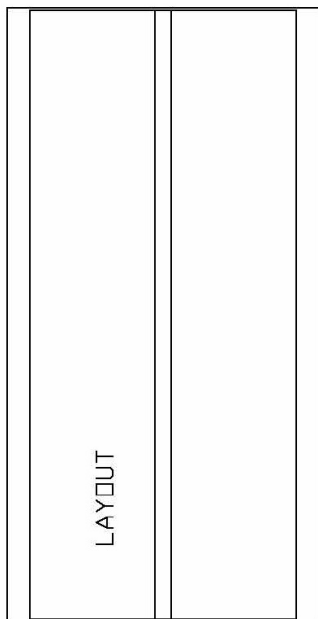
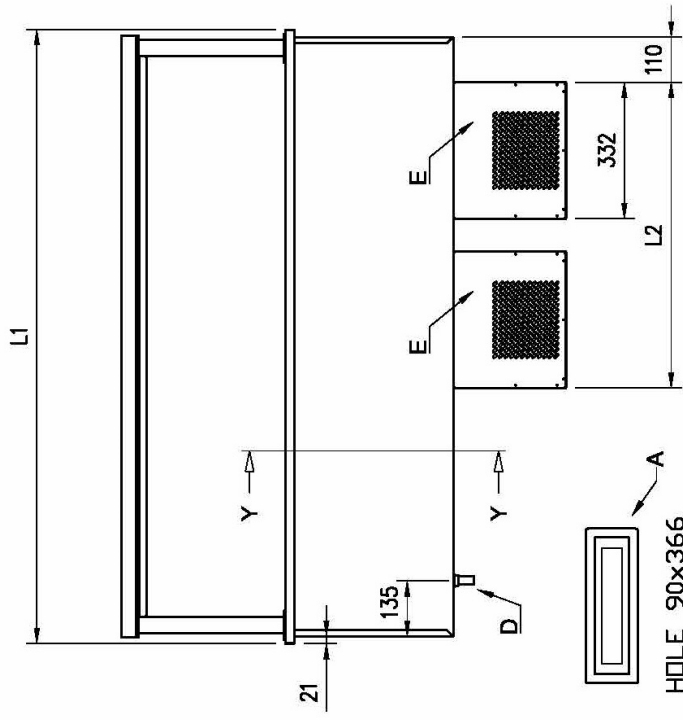
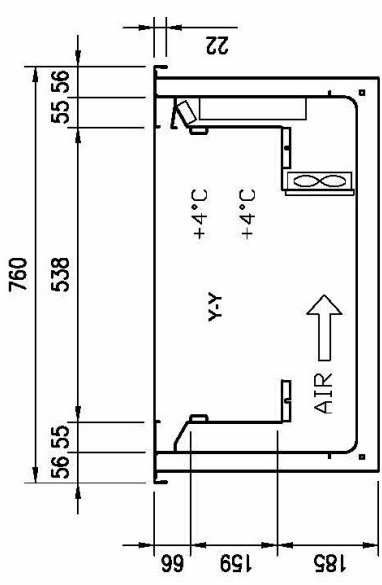

- A= ELECTRICAL CONNECTION
- D= WATER DISCHARGE ø16
- E= GAS CONNECTION ø8 ø10
- F= WATER BOX