

## BLUE PLATINUM PLUS 5 DF/DS

Ref: 1



(Mod. R)

Ref: 2

**Temperature range/Range di temperatura +4/+8° C**

**Doors, drawers/porte, cassetti**

Cold blown-air display units for self-service, with vertical refrigeration for the temporary display of food in pans (max. H 200mm) or at the well bottom. Models for 3, 4, 5 GN1 /1 pans (not included). Serviceable evaporator compartment in order to guarantee a perfect hygiene and an easy cleaning. Units are provided with condensing unit or ready for remote connection (R). Customer side closed with flaps (DF) or sliding glass (DS). Glass overstructure with 3 shelves and LED lighting.

*Vetrine refrigerate per libero servizio, con ventilazione canalizzata verticalmente per l'esposizione temporanea di prodotti contenuti in vaschette (max H 200mm) o in appoggio sul fondo. Modelli per 3, 4, 5 vaschette GN1/1 (non comprese). Vano evaporatore ispezionabile per una completa igiene e facilità di pulizia. Versioni con gruppo incorporato o predisposte per connessione remota (R). Lato cliente chiuso con flaps (DF) o con vetri scorrevoli (DS). Lato operatore chiuso con 2 (mod. 3/1), 3 (mod. 4/1) e 4 (mod. 5/1) porte battenti. Sovrastruttura e 3 ripiani in vetro con illuminazione LED.*

**Maximum Shelves N°/ Max Ripiani N°:**

**Maximum Pans N°/ Max Vaschette N°: 5 GN 1/1**

All specifications are subject to change without notice. *Dati tecnici soggetti a modifiche senza preavviso.*

The Picture (Ref: 1), the description (Ref: 2) and the technical drawing (Ref: 5) refer to the product range. Dimensional Data (Ref: 3) and Technical Data (Ref: 4) refer to the specific code (Ref: 6).

*L'immagine (Ref: 1), la descrizione (Ref: 2) e il disegno tecnico (Ref: 5) sono relativi alla famiglia prodotto. Dati di dimensione (Ref: 3) e Dati Tecnici (Ref: 4) sono specifici del codice indicato (Ref: 6).*

Afinox s.r.l. via Venezia 4 - 35010 - Campo San Martino - Padova (PD) - ITALY - Tel. +39 0499638311 / e-mail: comm@afinox.com / web: www.afinox.com

Ref: 6 Code/Codice 7DRPL5FIV0A01

Pag. 1 / 3

Rev.: 1 / 2021

**Dimensional Data/Dati di dimensione:**

Ref: 3

External dimensions (mm) WxDxH <i>Dimensioni Esterne (mm) LxPxH</i>	1819x760x1485	Insulation Thickness (mm) <i>Spessore di isolamento (mm)</i>	40
Internal Dimensions (mm) WxDxH <i>Dimensioni interne (mm) LxPxH</i>		Internal Volume (l) <i>Volume Interno (l)</i>	
Packing Dimensions (mm) WxDxH <i>Dimensioni Imballo (mm) LxPxH</i>	1883x860x1830	Gross Weight (Kg) <i>Peso Lordo (Kg)</i>	0
		Net Weight (Kg) <i>Peso Netto (Kg)</i>	0

**Technical Data/Dati Tecnici:**

Ref: 4

Power supply (V/Ph/Hz) <i>Alimentazione (V/P/Hz)</i>	230 / 1 / 50	Noise (db) 5m <i>Rumore (db) 5m</i>	50
Yearly Energy Consumption (kWh/annum) <i>Consumo energetico Annuo (kWh/annum)</i>		Daily energy consumption (kWh/24h) <i>Consumo energetico 24H (kWh)</i>	
Nominal power consumption (W) <i>Potenza assorbita (W)</i>	494** 15,36#	Maximum absorbed current (A) <i>Massima corrente assorbita (A)</i>	10,06
Energy efficiency class <i>Classe Energetica</i>		Climatic Class <i>Classe Climatica</i>	3 (25°C - 60%)
Blast chilling yield (Kg) *** <i>Resa Abbattimento (Kg) ***</i>		Refrigerating power (W) <i>Potenza Frigorifera (W)</i>	1044**
Shock freezing yield (Kg) *** <i>Resa Surgelazione (Kg) ***</i>		Gas	R290 - GWP 3 - Kg 0,100 + 0,15
Compressor/ <i>Compressore</i>		Controller	EVX
EMT6165U x 2			

\* (-30/+45° C), \*\*(-10/+45° C)

# Hood/Sovrastruttura

\*\*\* The blast chilling &amp; shock freezing yields, expressed in Kg or lb are indicative and not binding. The food cooling time depends on its composition and sizing. The actual cooling time for various food might be different from the indicated one.

\*\*\* Le rese in abbattimento e in surgelazione espresse in Kg o lb sono indicative e non vincolanti. Il tempo di raffreddamento degli alimenti dipende dalla loro composizione e dimensione. Il tempo di raffreddamento reale dei vari alimenti, potrebbe essere diverso da quello indicato.

All specifications are subject to change without notice. *Dati tecnici soggetti a modifiche senza preavviso.*

The Picture (Ref: 1), the description (Ref: 2) and the technical drawing (Ref: 5) refer to the product range. Dimensional Data (Ref: 3) and Technical Data (Ref: 4) refer to the specific code (Ref: 6).

*L'immagine (Ref: 1), la descrizione (Ref: 2) e il disegno tecnico (Ref: 5) sono relativi alla famiglia prodotto. Dati di dimensione (Ref: 3) e Dati Tecnici (Ref: 4) sono specifici del codice indicato (Ref: 6).*

Afinox s.r.l. via Venezia 4 - 35010 - Campo San Martino - Padova (PD) - ITALY - Tel. +39 0499638311 / e-mail: comm@afinox.com / web: www.afinox.com

Ref: 6 Code/Codice 7DRPL5FIV0A01

Pag. 2 / 3

Rev.: 1 / 2021

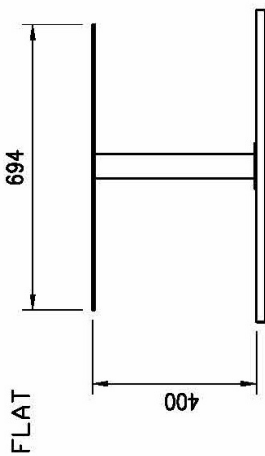

FLAT

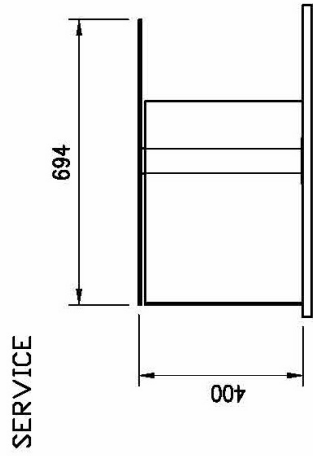

SERVICE

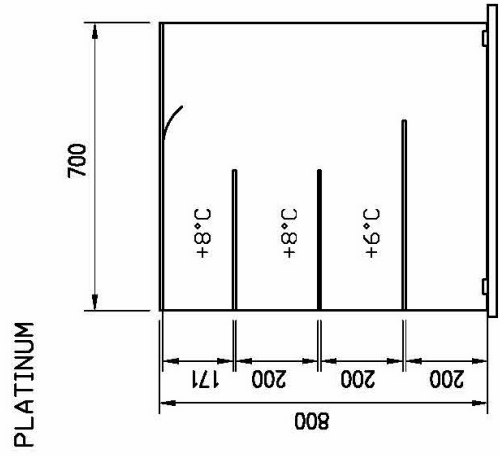

PLATINUM

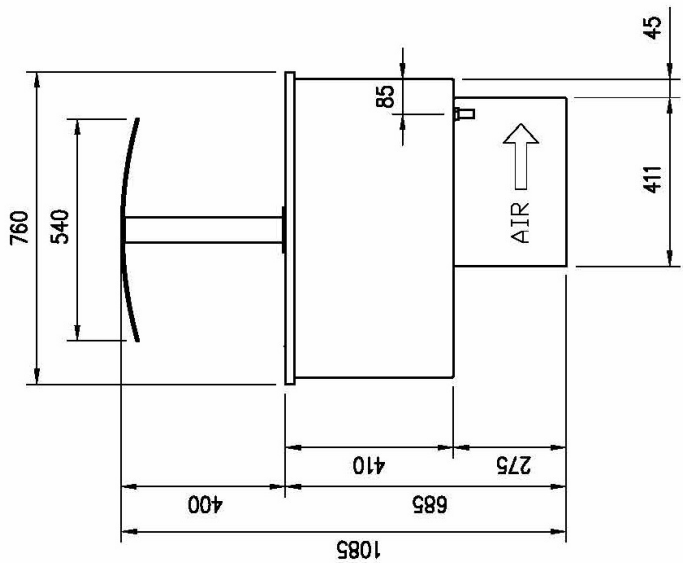

GN	L1	L2	HOLE
4/1	1494	744	1460x726
5/1	1819	744	1785x726
6/1	2144	1069	2110x726

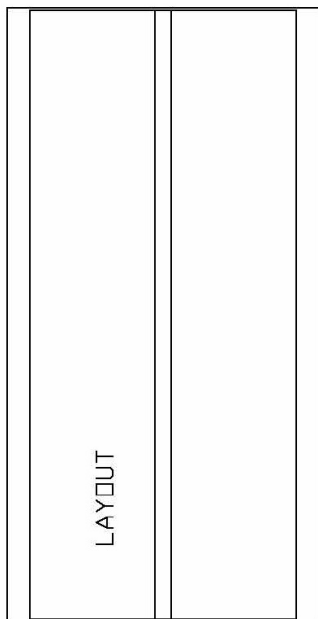
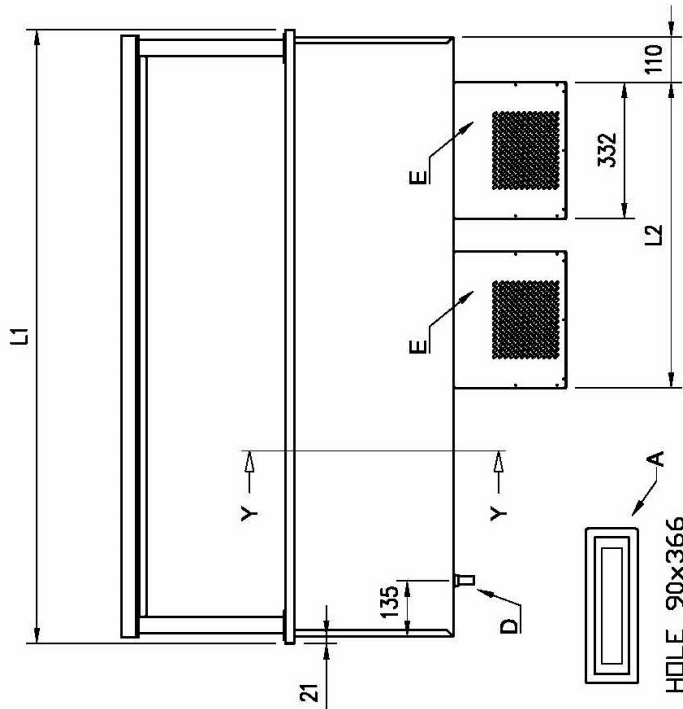
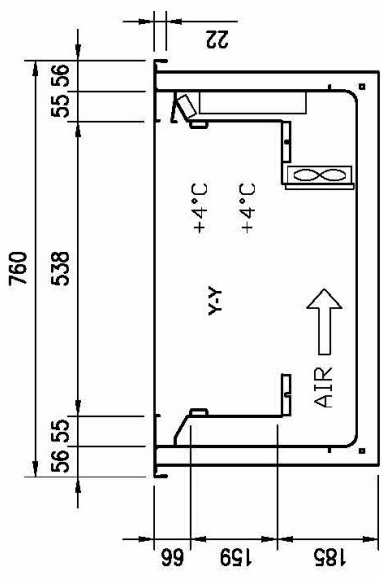

- A= ELECTRICAL CONNECTION
- D= WATER DISCHARGE ø16
- E= GAS CONNECTION ø8 ø10
- F= WATER BOX