

GN	L1	L2
4/1	1494	744
6/1	2144	1069

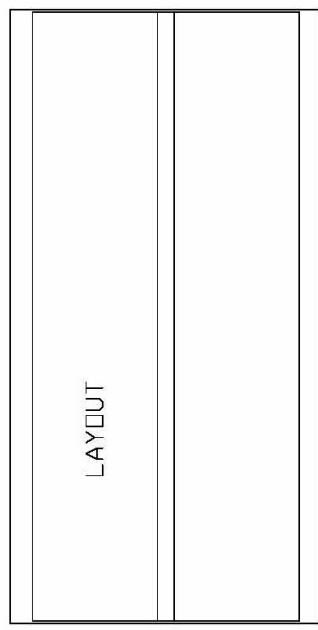
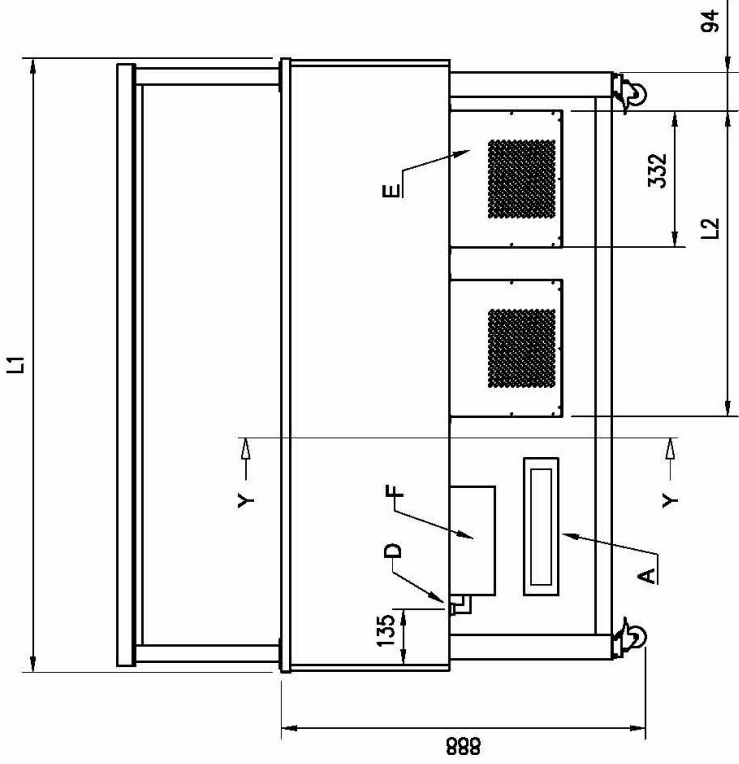
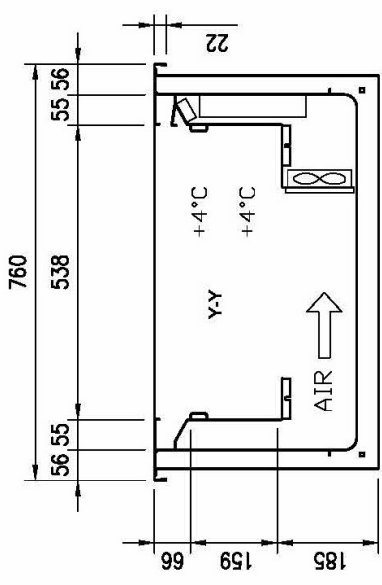

- A= ELECTRICAL CONNECTION
- D= WATER DISCHARGE Ø16
- E= GAS CONNECTION Ø8 Ø10
- F= WATER BOX