

# ESSENCE BROWN PLUS 6

Ref: 1

Ref: 2

Temperature range/Range di temperatura

**+60/+99 °C**

Technical drawing area containing various symbols and codes, including a barcode-like structure at the bottom.

**Maximum Shelves N°/ Max Ripiani N°:**

**Maximum Pans N°/ Max Vaschette N°: 6 GN 1/1**

All specifications are subject to change without notice. *Dati tecnici soggetti a modifiche senza preavviso.*

The Picture (Ref: 1), the description (Ref: 2) and the technical drawing (Ref: 5) refer to the product range. Dimensional Data (Ref: 3) and Technical Data (Ref: 4) refer to the specific code (Ref: 6).

*L'immagine (Ref: 1), la descrizione (Ref: 2) e il disegno tecnico (Ref: 5) sono relativi alla famiglia prodotto. Dati di dimensione (Ref: 3) e Dati Tecnici (Ref: 4) sono specifici del codice indicato (Ref: 6).*

**Afinox s.r.l.** via Venezia 4 - 35010 - Campo San Martino - Padova (PD) - ITALY - Tel. +39 0499638311 / e-mail: comm@afinox.com / web: www.afinox.com

**Dimensional Data/Dati di dimensione:**

Ref: 3

External dimensions (mm) WxDxH <i>Dimensioni Esterne (mm) LxPxH</i>	2144x650x1288	Insulation Thickness (mm) <i>Spessore di isolamento (mm)</i>	
Internal Dimensions (mm) WxDxH <i>Dimensioni interne (mm) LxPxH</i>		Internal Volume (l) <i>Volume Interno (l)</i>	
Packing Dimensions (mm) WxDxH <i>Dimensioni Imballo (mm) LxPxH</i>	2208x750x1595	Gross Weight (Kg) <i>Peso Lordo (Kg)</i>	146
		Net Weight (Kg) <i>Peso Netto (Kg)</i>	131

**Technical Data/Dati Tecnici:**

Ref: 4

Power supply (V/Ph/Hz) <i>Alimentazione (V/P/Hz)</i>	230 / 1 / 50	Noise (db) 5m <i>Rumore (db) 5m</i>	
Yearly Energy Consumption (kWh/annum) <i>Consumo energetico Annuo (kWh/annum)</i>		Daily energy consumption (kWh/24h) <i>Consumo energetico 24H (kWh)</i>	
Nominal power consumption (W) <i>Potenza assorbita (W)</i>	1710 800#	Maximum absorbed current (A) <i>Massima corrente assorbita (A)</i>	10,913
Energy efficiency class <i>Classe Energetica</i>		Climatic Class <i>Classe Climatica</i>	3 (25°C - 60%)
Blast chilling yield (Kg) *** <i>Resa Abbattimento (Kg) ***</i>		Refrigerating power (W) <i>Potenza Frigorifera (W)</i>	
Shock freezing yield (Kg) *** <i>Resa Surgelazione (Kg) ***</i>		Gas	
Compressor/ <i>Compressore</i>		Controller EVX	

\* (-30/+45° C), \*\*(-10/+45° C) # Hood/Sovrastruttura

\*\*\* The blast chilling & shock freezing yields, expressed in Kg or lb are indicative and not binding. The food cooling time depends on its composition and sizing. The actual cooling time for various food might be different from the indicated one.

\*\*\* Le rese in abbattimento e in surgelazione espresse in Kg o lb sono indicative e non vincolanti. Il tempo di raffreddamento degli alimenti dipende dalla loro composizione e dimensione. Il tempo di raffreddamento reale dei vari alimenti, potrebbe essere diverso da quello indicato.

All specifications are subject to change without notice. *Dati tecnici soggetti a modifiche senza preavviso.*

The Picture (Ref: 1), the description (Ref: 2) and the technical drawing (Ref: 5) refer to the product range. Dimensional Data (Ref: 3) and Technical Data (Ref: 4) refer to the specific code (Ref: 6).

*L'immagine (Ref: 1), la descrizione (Ref: 2) e il disegno tecnico (Ref: 5) sono relativi alla famiglia prodotto. Dati di dimensione (Ref: 3) e Dati Tecnici (Ref: 4) sono specifici del codice indicato (Ref: 6).*

Afinox s.r.l. via Venezia 4 - 35010 - Campo San Martino - Padova (PD) - ITALY - Tel. +39 0499638311 / e-mail: comm@afinox.com / web: www.afinox.com

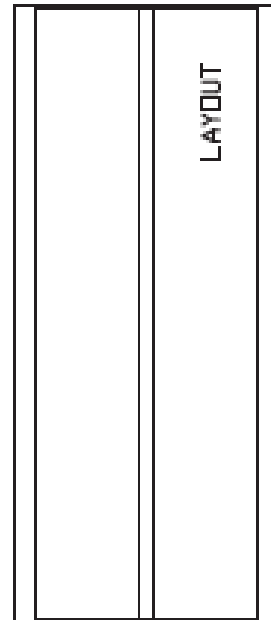
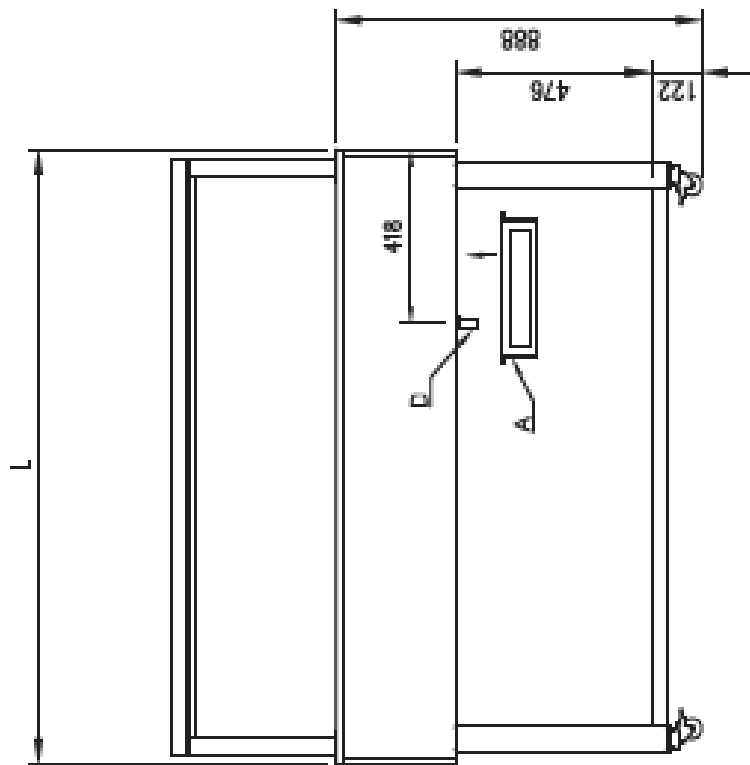
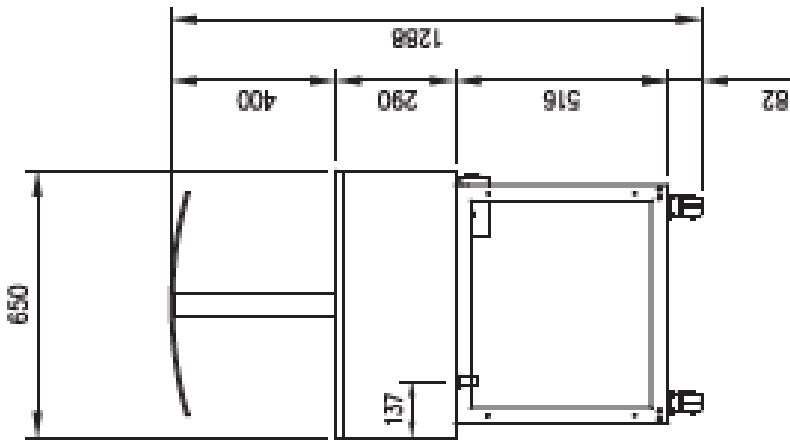
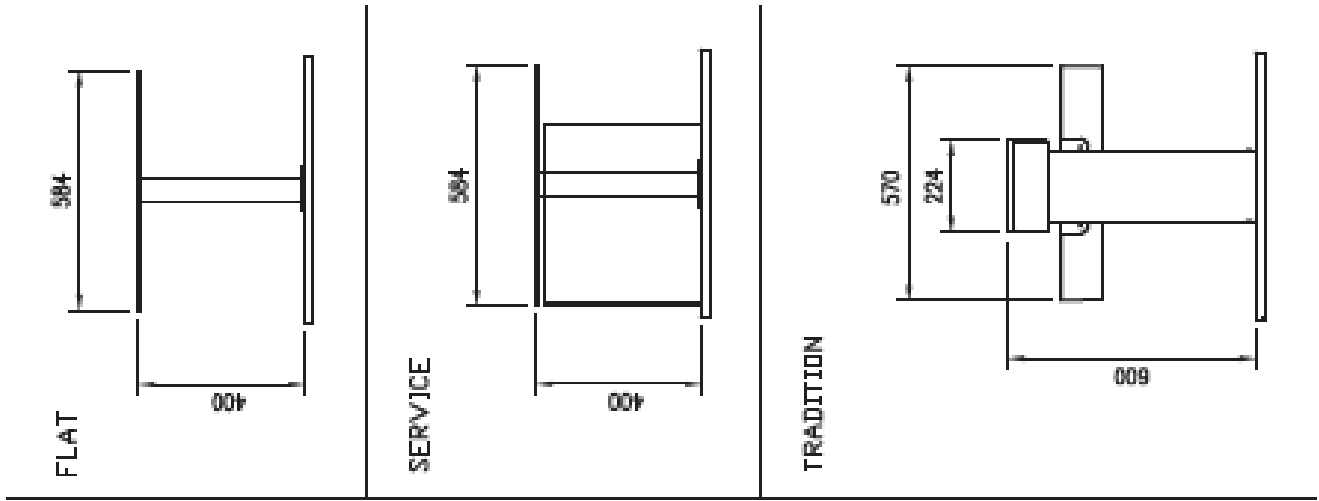

GN	L
3/1	1169
4/1	1494
6/1	2144

A= ELECTRICAL CONNECTION  
 D= WATER DISCHARGE Ø14

All specifications are subject to change without notice. *Dati tecnici soggetti a modifiche senza preavviso.*

The Picture (Ref: 1), the description (Ref: 2) and the technical drawing (Ref: 5) refer to the product range. Dimensional Data (Ref: 3) and Technical Data (Ref: 4) refer to the specific code (Ref: 6).

*L'immagine (Ref: 1), la descrizione (Ref: 2) e il disegno tecnico (Ref: 5) sono relativi alla famiglia prodotto. Dati di dimensione (Ref: 3) e Dati Tecnici (Ref: 4) sono specifici del codice indicato (Ref: 6).*

Afinox s.r.l. via Venezia 4 - 35010 - Campo San Martino - Padova (PD) - ITALY - Tel. +39 0499638311 / e-mail: comm@afinox.com / web: www.afinox.com